

Above Ground Domestic Tank

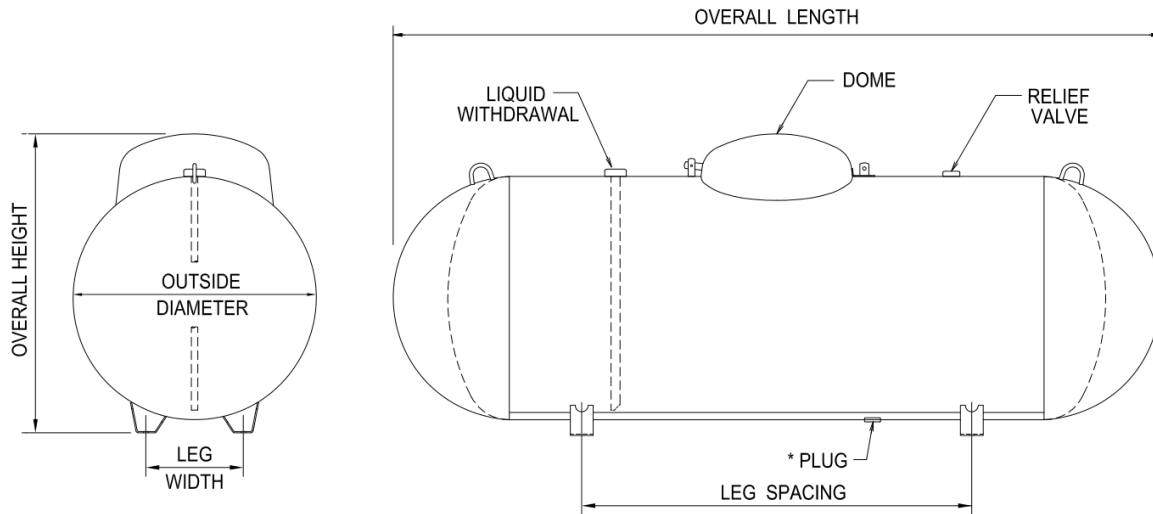

General Specifications

Conforms to the latest edition and addenda of the ASME code for Pressure Vessels, Section VIII, Division 1. Complies with NFPA 58.

Rated at 250 psig from -20° F. to 125° F. All tanks may be evacuated to a full (14.7 psi) vacuum.

Vessel Finish: Coated with TGIC powder.

Liquid withdrawal opening located under the dome on the 120wg vessels ONLY.

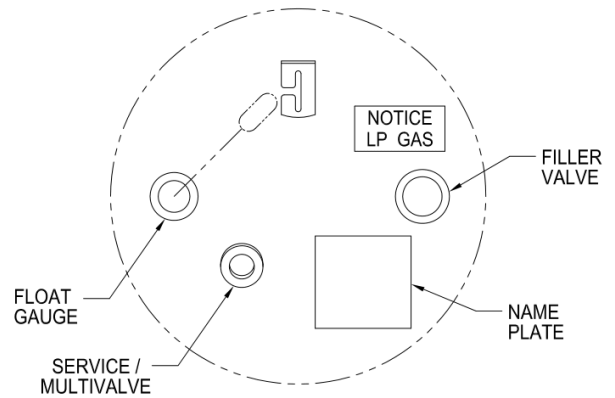

| ABOVEGROUND VESSEL DIMENSIONAL INFORMATION | | | | | | | | | |
|--|---------------------|-----------|------------------------------|----------------------------|---------------------|--------------------------|------------------------|-----------|-----------|
| All vessels dimensions are approximate | | | | | | | | | |
| WATER CAPACITY | OUTSIDE DIAMETER | HEAD TYPE | OVERALL LENGTH | OVERALL HEIGHT | LEG WIDTH | LEG SPACING | WEIGHT | QUANTITY | |
| | | | | | | | | FULL LOAD | PER STACK |
| * 120 wg. 454.2 L | 24" 609.6 mm | Ellip | 5' - 5 13/16" 1671.6 mm | 2' - 8 1/4" 819.2 mm | 10 1/8" 257.2 mm | 3' - 0" 914.4 mm | 245 lbs. 111.1 kg. | 96 | 12 |
| * 250 wg. 946.3 L | 31.5" 800.1 mm | Hemi | 7' - 2 1/2" 2197.1 mm | 3' - 3 3/4" 1009.7 mm | 12 3/4" 323.9 mm | 3' - 6" 1066.8 mm | 472 lbs. 214.1 kg. | 63 | 9 |
| * 320 wg. 1211.2 L | 31.5" 800.1 mm | Hemi | 8' - 11 3/4" 2736.9 mm | 3' - 3 3/4" 1009.7 mm | 12 3/4" 323.9 mm | 4' - 0 1/4" 1225.6 mm | 588 lbs. 266.7 kg. | 45 | 9 |
| 500 wg. 1892.5 L | 37.42" 950.5 mm | Hemi | 9' - 10" 2997.2 mm | 3' - 9 11/16" 1160.5 mm | 15" 381.0 mm | 5' - 0" 1524.0 mm | 871 lbs. 395.1 kg | 30 | 6 |
| 1000 wg. 3785.0 L | 40.96" 1040.4 mm | Hemi | 15' - 10 13/16" 4846.6 mm | 4' - 1 3/8" 1254.1 mm | 16 1/4" 412.8 mm | 9' - 0" 2743.2 mm | 1729 lbs. 784.3 kg | 15 | 5 |
| 1465 wg. 5545.0 L | 46.77" 1188 mm | Ellip | 17' - 6 7/8" 5356.2 mm | 4' - 4 3/4" 1339.9 mm | 21" 533.4 mm | 10' - 0" 3048 mm | 2745 lbs. 1245 kg | 12 | 4 |
| 2000 wg. 7570.0 L | 46.77" 1188 mm | Ellip | 23' - 9" 7239 mm | 4' - 7" 1709.7 mm | 21" 533.4 mm | 20' - 0" 6096 mm | 3676 lbs. 1667.5 kg | 8 | 4 |

* DRAIN PLUG NOT AVAILABLE